

# SERCO 8500

TRUCK MOUNT

TRAILER MOUNT

- 8500 LB. CAPACITY
- BOOM REACH OPTIONS TO 28'
- HIGH VISIBILITY OPERATOR PLATFORM WITH OUT-OF-THE-WAY VALVE ARRANGEMENTS
- RUGGED HIGH QUALITY CONSTRUCTION & COMPONENTS





# SERCO 8500



## GENERAL SPECIFICATIONS

### LIFT CAPACITY

- 8500 lbs. @ 10' radius (less weight of attachment).

### BOOM REACH

- 22' fixed length boom standard. Fixed length and telescoping booms available to 28'.

### ROTATION

- Continuous on turntable bearing.

### WEIGHT

- 7,500 lbs. (including oil & continuous grapple).

## STANDARD FEATURES

### MAIN AND SECONDARY BOOMS

- Fabricated from 80,000 PSI yield strength plate and reinforced at all stress points

### BOOM CYLINDERS

- Double acting with ductile iron pistons and glands with wear rings and chrome plated shafts. Main lift cylinder 5-1/2" x 36" x 3". Secondary boom cylinder 5" x 35-1/2" x 2-1/2".

### BOOM PIVOT PINS

- 2-1/2" diameter made from 100,000 PSI yield chrome plated shafting.

### BUSHINGS

- Aluminum bronze bushings at boom pivot points.

**MODELS RANGING UP TO 37,000 LBS.  
LIFT CAPACITY**

SPECIFICATIONS SUBJECT TO CHANGE  
WITHOUT PRIOR NOTICE

## SWING SYSTEM

- Hydraulic motor powered double planetary gearbox driving external tooth turntable bearing.
- Crossover relief valve for swing motor protection.

## STABILIZERS

- Telescoping A-frame type with 117-3/4" spread at grade level individually controlled from operator's seat for adjustment on uneven terrain.
- Double acting 3-1/2" x 44" x 2" cylinders.

## HYDRAULIC SYSTEM

- Tandem hydraulic circuits to allow simultaneous operation without power loss.
- Tandem gear pump providing 30 & 30 GPM at 1400 pump RPM.
- Stack type control valve located under seat for increased operator visibility and safety. Including necessary relief and anti-cavitation valves for machine protection.
- 50 gallon A-frame mounted hydraulic reservoir with high capacity, 10-micron return line filter and removable access cover.
- Folding joystick controls standard. 4-wire reinforced hoses in all pressure applications.
- SERCO hydraulic manifold with ductile iron center spool & chrome plated housing for continuous swing rotation.

## MISCELLANEOUS

- 2-Point greasing system for turntable bearing and pinion gear.
- Mechanical swing lock for safety during transit
- Dual heavy duty ladders.

## OPTIONS

- Telescoping jib boom with separate valve and foot control.
- Light kits.
- Full range of attachments including continuous rotation grapples.
- Side mounted steel or aluminum tank built to SERCO specs.
- Hydraulic Oil Coolers

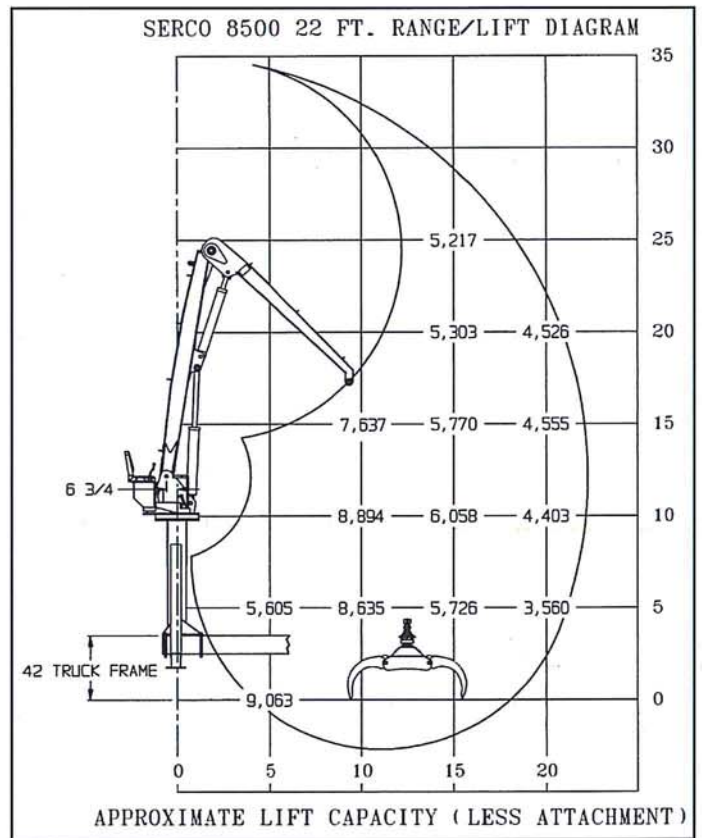

# SERCO LOADERS

611 2nd Ave.

Two Harbors, MN 55616

Phone: (218) 834-5118

FAX: (218) 834-2498

Email: serco@sercoloaders.com

Web: www.sercoloaders.com



PRINTED IN USA